

# MYTORQ

ANLIDAR INDUSTRIAL CO.,LTD.



**INNOVATION  
FOR SCREWS  
FASTENING**

**LOW TORQUE**

**CATALOGUE**



# HOW WE NAME MYTORQ SCREWDRIVER

## MY 2 - 0235LFD(VB)



Post 1 : MYTORQ Series

Post 2 : Torque Range

Post 3 : Start Type. "L"-Trigger Start, "P"-Push Start

Post 4 : "F"-High Speed

Post 5 : Bit Type

"A"-Bit in SS 5mm Hexagon 

"B"-Bit in SS 6.35mm Hexagon 

"C"-Bit in M3 4Ø Round 

"D"-Bit in M6 5Ø Round 

Post 6 : Vacuum Pick up Type



**TABLE OF ALL MODELS**

Page	Series	Specifications						Power
		Model	Torque(kgf.cm)	Speed(r.p.m)	Screw Size (mm)	Features	Starting Method	Model
7	MY2	MY2-0235L	0.2~3.5	1000	1.0~2.3	Low Torque Screwdriver	Trigger Start	MYP32-60
		MY2-0235LS5/LS6/LS7	0.2~3.5	500(370)(230)	1.0~2.3			
		MY2-0507L	0.5~7	1000	1.4~2.6			
		MY2-0110L, MY2-0210P	1~10(2~10)	1000	1.6~3.0			
8	MY5	MY5-0212L/P	1.5~12(2~12)	1000	1.6~3.0	Medium Torque Screwdriver	Trigger or Push Start	MYP32-300
		MY5-0212LF/PF	1.5~12(2~12)	2000	1.6~3.0			
		MY5-0317LF/PF	3~17	2000	2.3~3.5			
		MY5-0319L/P	3~19	1000	2.3~3.5			
9	MY2-EP	MY2-EP0235L	0.2~3.5	1000	1.0~2.3	Low Torque Screwdriver Built-in Counter	Trigger Start	MYP32-60
		MY2-EP0235LS5/LS6/LS7	0.2~3.5	500(370)(230)	1.0~2.3			
		MY2-EP0507L	0.5~7	1000	1.4~2.6			
		MY2-EP0110L/P	1~10(2~10)	1000	1.6~3.0			
10	MY5-EP	MY5-EP0212L/P	1.5~12(2~12)	1000	1.6~3.0	Medium Torque Screwdriver Built-in Counter	Trigger or Push Start	MYP32-300
		MY5-EP0212LF/PF	1.5~12(2~12)	2000	1.6~3.0			
		MY5-EP0317LF/PF	3~17	2000	2.3~3.5			
		MY5-EP0319L/P	3~19	1000	2.3~3.5			
11	MY2-(VB)	MY2-0235L	0.2~3.5	1000	1.0~2.3	Low Torque Screwdriver with Vacuum	Trigger Start	MYP32-60
		MY2-0235LS5/LS6/LS7	0.2~3.5	500(370)(230)	1.0~2.3			
		MY2-0507L	0.5~7	1000	1.4~2.6			
		MY2-0110L, MY2-0210P	1~10(2~10)	1000	1.6~3.0			
12	MY5-(VB)	MY5-0212L/P	1.5~12(2~12)	1000	1.6~3.0	Medium Torque Screwdriver with Vacuum	Trigger or Push Start	MYP32-300
		MY5-0212LF/PF	1.5~12(2~12)	2000	1.6~3.0			
		MY5-0317LF/PF	3~17	2000	2.3~3.5			MYP32-60
		MY5-0319L/P	3~19	1000	2.3~3.5			

**TORQUE OF ALL MODELS(kgf.cm)**



(1kgf.cm=0.098N.m, 1N.m=8.85Lbf.in, 1N.m=10.2kgf.cm)

# MYTORQ INDUSTRY 4.0

## Torque Read Out Controller

MY-TR



MY-TR



### External Dimension

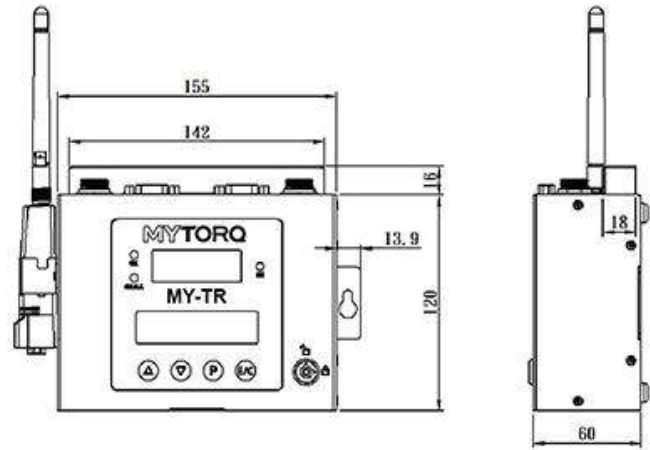

MY-TR

### Features

In the era of industry 4.0, assembly data collection and integration is becoming a must. In order to meet market demands, Anlidar's latest invention MY-TR is able to display tightening torque, output tightening torque, output tightening status, storage tightening torque and together with error proof functions.

MY-TR is also able to prevent errors from tightening torque, tightening number of threads, and tightening time. With various I/O, MY-TR can be connected to your PLC and integrated with your automation equipment and output assembly status instantly to your sever or private cloud by ethernet or WIFI for traceability.



### Specifications

Model	MY-TR
Input Voltage	DC 32V/ 40V
I/O Output Voltage	DC 24V 50mA/12V 100mA
Batch Count	1-99
Count method	Count-up / Count-down
Continued induction switch(sensor)	ON/OFF
Sensor switch mode	ON(2 Sensors) / OFF(1 Sensor)
Slow start time setting	0~9.9 seconds
Slow start speed setting	L0:100%,10%~90% L1~L9 Rated speed
Stop time detection	0.00~9.99 seconds
Torque value detection	0.0~550.0 kgf.cm
Screw thread detection	0.0~999.9
External signal input	Forward / Reverse / Disable / Confirm
External signal output	OK / NG / OK ALL / STOP
Serial interface	RS-232X2
Assembly management	MY-DAS / MY-AMS
external dimensions	155X120X60(mm)
Weight(g)	622.5g
Accessories	Power cableX1 KeyX2
Applicable Models	MY2-TR MYT-TR MY5-TR MY7-TR MY8-TR MY9-TR MYR-TR MYLR-TR

### MY-TR

#### Product Features

- 4 digits and 7 Segment of torque display
- 16 x 2 LCM display settings
- Password and key control to avoid operator adjusting settings.
- Counting preference set up (count up and count down)
- Slow start time 0.0-9.9 sec
- Slow start speed (10%~90%,L1~L9)
- Workpiece in position sensor (on/off)
- Monitor fastening thread range
- I/O signal (Optocoupler)
- RS-232 interface for data output, storage and use with barcode scanner
- Save up to 99 programs
- Monitor fastening time range
- Monitor fastening torque range
- Error code
- Auto learning
- Change torque unit
- Offset setting
- External start
- External reverse
- External disable tool
- External confirm

#### MY-TR System Schematic (MY-TR(5) Applicable to TR Series Screwdrivers)

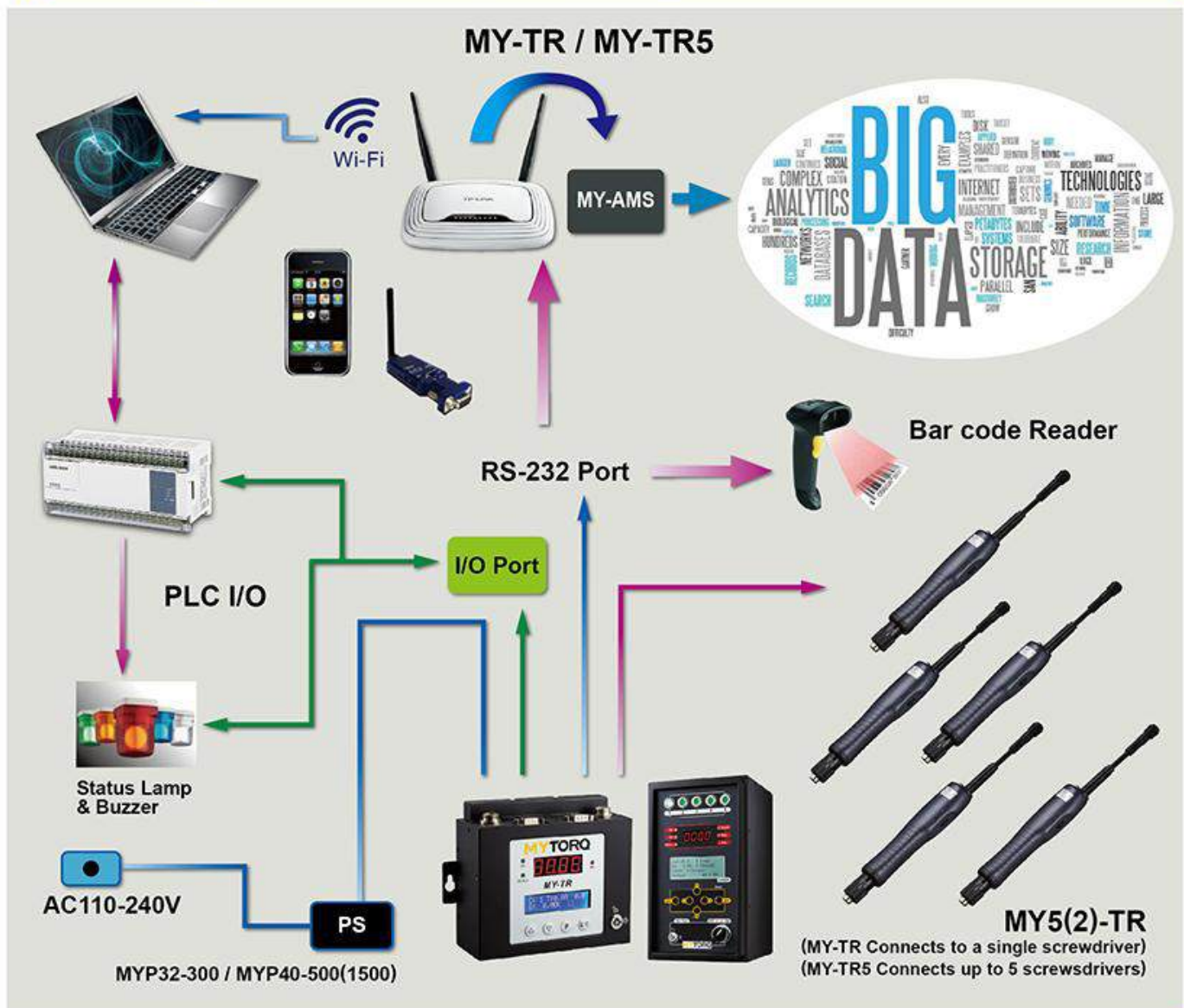

# MYTORQ INDUSTRY 4.0

## Torque Read Out Controller

MY-TR5



MY-TR5

### External Dimension

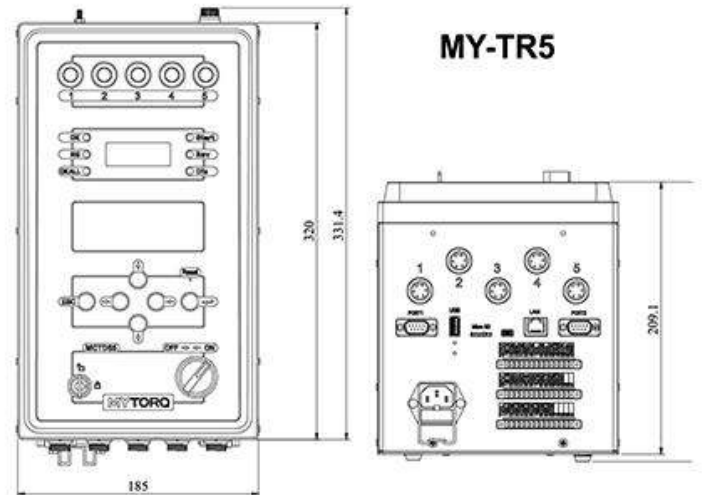

MY-TR5

### Features

- 4 digits and 7 Segment of torque display
- 24x4 LCM display settings
- Password and key control to avoid operator adjusting settings.
- Counting preference set up (count up and count down)
- Slow start time 0.0-9.9 sec
- Slow start speed (10%~90%,L1~L9)
- Workpiece in position sensor (on/off)
- Monitor fastening thread range
- I/O signal (Optocoupler)
- RS-232 interface for data output, storage and use with barcode scanner
- Save up to 99 programs
- Monitor fastening time range
- Monitor fastening torque range
- Error code
- Auto learning
- Change torque unit
- Offset setting
- External start
- External reverse
- External disable tool
- External confirm
- Slot for SD memory card
- Built-in power
- Ethernet
- Save up to 99 sequences

### Specifications

Model	MY-TR5
Input Voltage	AC 100V ~ 240V
I/O Output Voltage	DC 24V 50mA / 12V 100mA
Batch Count	1-99
Count method	Count-up / Count-down
Continued induction switch(sensor)	ON/OFF
Sensor switch mode	ON(2 Sensors) / OFF(1 Sensor)
Slow start time setting	0~9.9 seconds
Slow start speed setting	L0:100%,10%~90% L1~L9 Rated speed
Stop time detection	0.00~9.99 seconds
Torque value detection	0.0~550.0 kgf.cm
Screw thread detection	0.0~999.9
External signal input	Forward / Reverse / Disable / Confirm
External signal output	OK / NG / OK ALL / STOP
Serial interface	RS-232X2
Assembly management	MY-DAS / MY-AMS
External dimensions	185 x320x209(mm)
Weight	5.55KG
Accessories	Power cableX1 KeyX2
Applicable Models	MY2-TR MYT-TR MY5-TR MY7-TR MY8-TR MY9-TR MYR-TR MYLR-TR

# POWER CONTROLLER

## MYP Series [MYP32-60, MYP32-300]



### External Dimension

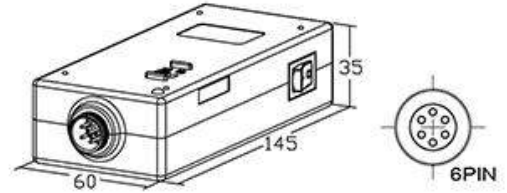



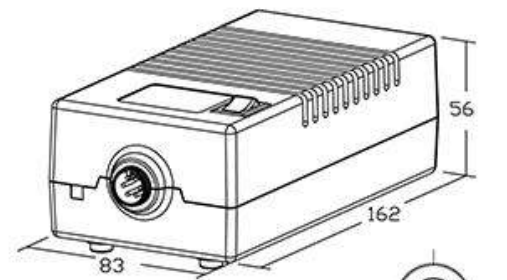

MYP32-60



MYP32-300

- Power switch : ON/OFF indicator. Two kinds of output voltage Hi & Lo.
- Please set the torque scale below 4 for operation when the voltage of MYP series is set as Lo or below 32V.
- Support various plug type for different countries.

### Specifications

Model	MYP32-60	MYP32-300
Input Voltage	AC 100-240V 50/60Hz	AC 100-240V 50/60Hz
Output Voltage	LO DC 24V / HI DC 32V	LO DC 24V / HI DC 32V
Capacity	1.8A MAX	3A MAX
Outside Dimensions	145X60X35(mm)	200X80X66(mm)
Weight(g)	250(main body)	460(main body)
AC Cord Length	2M with ground	2M with ground
Remark (optional)	   	
Applicable Models	MY2 Series MY2-EP Series MY5 Series (not includ fast speed type) MY5-EP Series (not includ fast speed type)	MY2-TR Series MY5-TR Series MY5 Series fast speed type MY5-EP Series fast speed type

### Plug Types

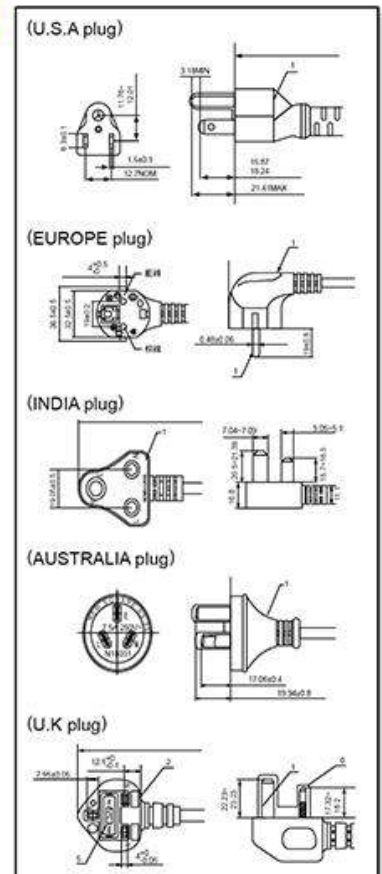

# BRUSHLESS LOW TORQUE DC-TYPE AUTO SHUT OFF TRIGGER AND PUSH START CLUTCH TYPE SERIES

MY2 / MY2-TR Series

 (optional)



## Torque Range Chart

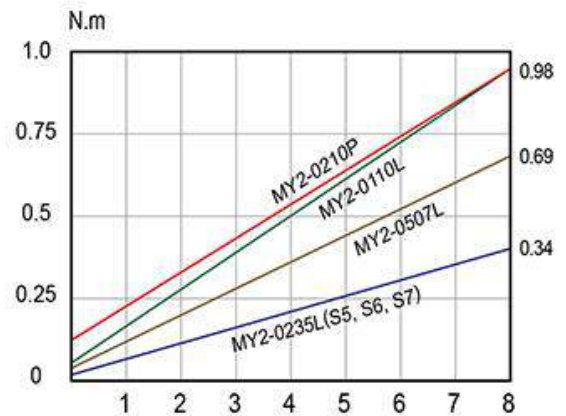

## Specifications

Model		MY2-0235L	MY2-0235LS5	MY2-0235LS6	MY2-0235LS7	MY2-0507L	MY2-0110L/MY2-0210P
		MY2-TR0235L	MY2-TR0235LS5	MY2-TR0235LS6	MY2-TR0235LS7	MY2-TR0507L	MY2-TR0110L/MY2-TR0210P
Input Voltage		DC24V or DC32V					
Power Consumption		25W					
Torque	(kgf.cm)	0.2~3.5				0.5~7	L:1~10 P:2~10
	(Lbf.in)	0.18~3.08				0.44~6.16	L:0.88~8.8 P:1.76~8.8
	(N.m)	0.02~0.34				0.05~0.69	L:0.10~0.98 P:0.2~0.98
Repeatable Torque Accuracy(%)		±3%					
Torque Adjustment		Stepless					
Free Speed (r.p.m)	HI	1000	500	370	230	1000	1000
	LO	700	350	260	160	700	700
Screw Size Dia (mm)	Machine Screw	1.0~2.3	1.0~2.3	1.0~2.3	1.0~2.3	1.4~2.6	1.6~3.0
	Tapping Screw	1.0~2.0	1.0~2.0	1.0~2.0	1.0~2.0	1.4~2.3	1.6~2.6
Weight(g)		L:330 P:310					
Length(mm)		L:185 P:230					
ESD(Anti-Static)		✓ (with black housing)					
CE		✓					
RoHS		✓					
Bit Type							

※MY2-0235LS can not work with KL-SSBN slow start control module

## Accessories





# BRUSHLESS MEDIUM TORQUE DC-TYPE AUTO SHUT OFF TRIGGER AND PUSH START CLUTCH TYPE SERIES

**MYTORQ**  
ANLIDAR INDUSTRIAL CO.,LTD.

## MY5 / MY5-TR Series

 (optional)

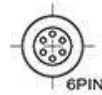

### Torque Range Chart

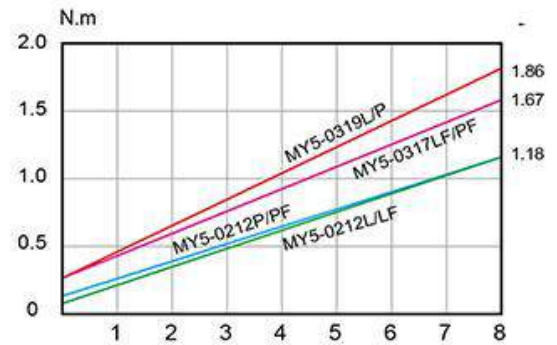

### Specifications

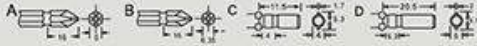
Model		MY5-0212L MY5-TR0212L	MY5-0212P MY5-TR0212P	MY5-0212LF MY5-TR0212LF	MY5-0212PF MY5-TR0212PF	MY5-0317L/PF MY5-TR0317L/PF	MY5-TR0319L/P MY5-TR0319L/P
Input Voltage		DC24V or DC32V					
Power Consumption		55W					
Torque	(kgf.cm)	1.5~12	2~12	1.5~12	2~12	3~17	3~19
	(Lbf.in)	1.33~10.44	1.77~10.44	1.32~10.56	1.76~10.56	2.64~14.96	2.57~16.46
	(N.m)	0.15~1.18	0.2~1.18	0.15~1.18	0.19~1.18	0.29~1.67	0.29~1.86
Repeatable Torque Accuracy(%)		±3%					
Torque Adjustment		Stepless					
Free Speed (r.p.m)	HI	1000	1000	2000	2000	2000	1000
	LO	700	700	—	—	—	700
Screw Size Dia (mm)	Machine Screw	1.6~3.0	1.6~3.0	1.6~3.0	1.6~3.0	1.6~3.0	2.3~3.5
	Tapping Screw	1.6~2.6	1.6~2.6	1.6~2.6	1.6~2.6	1.6~2.6	2.3~3.0
Weight(g)		520					
Length(mm)		245					
ESD(Anti-Static)		✓ (with black housing)					
CE		✓					
RoHS		✓					
Bit Type							

### Accessories



# BRUSHLESS LOW TORQUE DC-TYPE AUTO SHUT OFF WITH ERROR PROOF COUNTER TRIGGER AND PUSH START CLUTCH TYPE SERIES

## MY2-EP Series

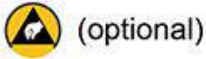

### Torque Range Chart

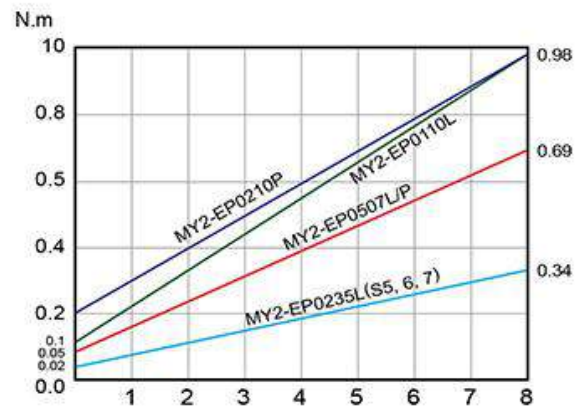

### Specifications

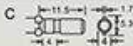
Model		MY2-EP0235L	MY2-EP0235LS5	MY2-EP0235LS6	MY2-EP0235LS7	MY2-EP0507L	MY2-EP0110L MY2-EP0210P
Input Voltage		DC24V or DC32V					
Power Consumption		25W					
Torque	(kgf.cm)	0.2~3.5				0.5~7	L:1~10 P:2~10
	(Lbf.in)	0.18~3.08				0.44~6.16	L:0.88~8.8 P:1.76~8.8
	(N.m)	0.02~0.34				0.05~0.69	L:0.10~0.98 P:0.2~0.98
Repeatable Torque Accuracy(%)		±3%					
Torque Adjustment		Stepless					
Free Speed (r.p.m)	HI	1000	500	370	230	1000	1000
	LO	700	350	260	160	700	700
Screw Size Dia (mm)	Machine Screw	1.0~2.3	1.0~2.3	1.0~2.3	1.0~2.3	1.4~2.6	1.6~3.0
	Tapping Screw	1.0~2.0	1.0~2.0	1.0~2.0	1.0~2.0	1.4~2.3	1.6~2.6
Weight(g)		L:330 / P:310					
Length(mm)		LC:226 / LB:240 / P:230					
ESD(Anti-Static)		✓ (with black housing)					
CE		✓					
RoHS		✓					
Bit Type							

### Accessories



\*\*Please contact your agent for special customization version.

# BRUSHLESS MEDIUM TORQUE DC-TYPE AUTO SHUT OFF WITH ERROR PROOF COUNTER TRIGGER AND PUSH START CLUTCH TYPE SERIES

**MYTORQ**  
ANLIDAR INDUSTRIAL CO.,LTD.

## MY5-EP Series

 (optional)

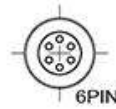

## Torque Range Chart

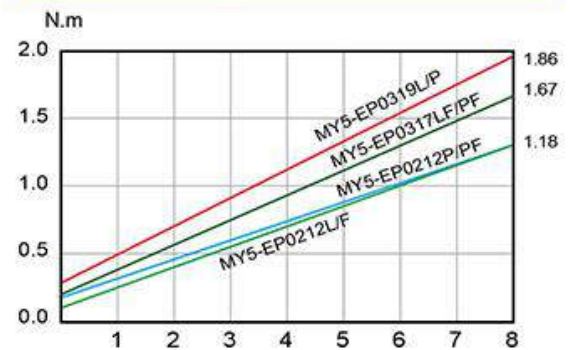

## Specifications

Model		MY5-EP0212L/P	MY5-EP0212L/P/PF	MY5-EP0317L/P/PF	MY5-EP0319L/P
Input Voltage		DC24V or DC32V			
Power Consumption		55W			
Torque	(kgf.cm)	L:1.5~12	P:2~12	LF:1.32~10.56	PF:1.76~10.56
	(Lbf.in)	L:1.32~10.56	P:1.76~10.56	LF:1.32~10.56	PF:1.76~10.56
	(N.m)	L:0.15~1.18	P:0.19~1.18	LF:0.15~1.18	PF:0.19~1.18
Repeatability Accuracy(%)		±3%			
Torque Adjustment		Stepless			
Free Speed (r.p.m)	HI	1000	2000	2000	1000
	LO	700	-	-	700
Screw Size Dia (mm)	Machine Screw	1.6~3.0	1.6~3.0	1.6~3.0	2.3~3.5
	Tapping Screw	1.6~2.6	1.6~2.6	1.6~2.6	2.3~3.0
Weight(g)		580			
Length(mm)		270			
ESD(Anti-Static)		✓ (with black housing)			
CE		✓			
RoHS		✓			
Bit Type					

## Accessories



\*\*Please contact your agent for special customization version.

# BRUSHLESS LOW TORQUE DC-TYPE AUTO SHUT OFF VACUUM PICK UP SERIES

## MY2 Series

 (optional)(VB)



\*\*Please contact your agent for special customization version.

### Specifications

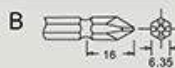
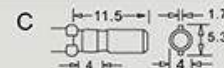
Mode		MY2-0235L(VB)	MY2-0507L(VB)	MY2-0110L(VB)	MY2-0235LS5(VB)	MY2-0235LS6(VB)	MY2-0235LS7(VB)
Input Voltage		DC24V or DC32V					
Torque	(kgf.cm)	0.2~3.5	0.5~7	L:1~10			0.2~3.5
	(Lbf.in)	0.18~3.01	0.44~6.16	L:0.88~8.8			0.18~3.08
	(N.m)	0.02~0.34	0.05~0.69	L:0.10~0.98			0.02~0.34
Repeatable Torque Accuracy(%)		±3%					
Torque Adjustment		Stepless					
Free Speed (r.p.m)	HI	1000	1000	1000	500	370	230
	LO	700	700	700	350	260	160
Screw Size Dia (mm)	Machine Screw	1.0~2.3	1.4~2.6	1.6~3.0	1.0~2.3	1.0~2.3	1.0~2.3
	Tapping Screw	1.0~2.0	1.4~2.3	1.6~2.6	1.0~2.0	1.0~2.0	1.0~2.0
Power Consumption		25W					
Weight(g)		385					
Length(mm)		234					
ESD(Anti-Static)		✓ (with black housing)					
CE		✓					
RoHS		✓					
Power Controller		MYP32-60					
Bit Type							

# BRUSHLESS MEDIUM TORQUE DC-TYPE AUTO SHUT OFF VACUUM PICK UP SERIES

## MY5 Series

 (optional) (VB)

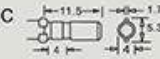
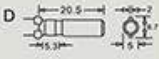

### Specifications

Model	MY5-0212L(VB)	MY5-0319L(VB)	MY5-0317LF(VB)	MY5-0212LF(VB)	
Input Voltage	DC24V or DC32V				
Torque	(kgf.cm)	1.5~12	3~19	3~17	1.5~12
	(Lbf.in)	1.32~10.56	2.64~16.72	2.64~14.96	1.32~10.56
	(N.m)	0.15~1.18	0.29~1.86	0.29~1.67	0.15~1.18
Repeatable Torque Accuracy(%)	±3%				
Torque Adjustment	Stepless				
Free Speed (r.p.m)	HI	1000	1000	2000	2000
	LO	700	700	---	---
Screw Size Dia (mm)	Machine Screw	1.6~3.0	2.3~3.5	1.6~3.0	1.6~3.0
	Tapping Screw	1.6~2.6	2.3~3.0	1.6~2.6	1.6~2.6
Power Consumption	55W				
Weight(g)	520				
Length(mm)	283				
ESD(Anti-Static)	✓ (with black housing)				
CE	✓				
RoHS	✓				
Power Controller	MYP32-60		MYP32-300		
Bit Type	  				

### Bit nozzle specification

PART NO	d1	d2	D	H	Applicable Model
P11032-7	2.2	3.2	4.2	1.3	MY2
P11032-8	2.7	4.2	5.2	1.3	
P11032-9	3.2	5	6	1.3	
P11032-10	3.5	5.5	6.5	1.3	
P11032-11	4.5	6.5	7.5	1.5	
P11032-15	3.5	5.5	6.5	2	MY5 MY8
P11032-17	4.5	6.5	7.5	2	
P11032-18	5.5	7.5	8.5	2	

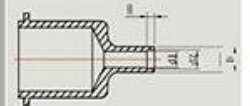

\*\*Please contact your agent for special customization version.

# ERROR PROOF COUNTER

## INTRODUCTION / FEATURES

### Introduction

In order to achieve accurate counting on screw fastening and work together with PLC based process control, ANLIDAR integrate screw counter, power supply, and slow start function into unique device which is both power supply and screw counter as well. Our screw counters are designed more conveniently and perfectly to meet users' practicability and availability.

### Features of MYPC32-100

- High / Low speed switch / Hi/Lo voltage switch protection function
- Slow start time (0.0-9.9 second)
- Slow start speed Level (L0:100%, 35%~85% L1~L9 Rated speed)
- Target reached Confirm (enable / disable)
- Input / Output function control
- External start Input Control
- External reverse Input Control
- External enable Input Control
- External confirm Input Control
- Expanding 5 sets data memory
- Auto-Learning function for time monitoring
- Before tightening reverse
- After tightening reverse
- Counting mode (count up / count down)
- Signal output (OK 1/ OK ALL / NG)
- Cancel NG signal (Use external Clear or Confirm button to cancel NG signal)
- Operation complete time
- Self locking when counter detect error (enable / disable)
- Sensor mode (Applications according to different operation use)
- Error code by monitoring
- Strong anti-interference capability

## MYPC32-100

MY2-0235L

MY5-0212L

MY5-0212LF

MY2-0507L

MY5-0212P

MY5-0212PF

MY2-0110L

MY5-0319L

MY5-0317LF

MY2-0210P

MY5-0319P

MY5-0317PF



# ERROR PROOF COUNTER

## MYPC32-100 [Error Proof / Power Supply]



### External Dimension

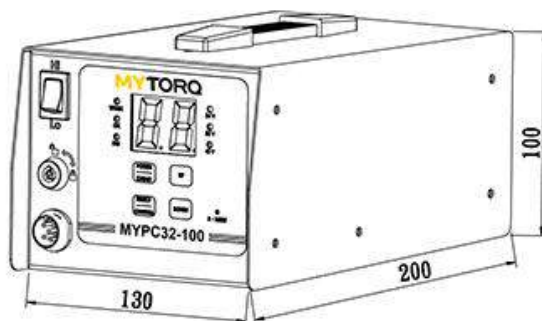

### Specifications

Model	MYPC32-100
Input Voltage	AC 100~240V 50/60HZ
Output Voltage	DC 32V / 24V 1.875A
Power Consumption	60W
Count	1~99
Count method	Count-up / Count-down
Work with Sensor	ON / OFF
GATE Sensor	ON(2 Sensors) / OFF(1 Sensor)
Slow-start time adjustable	0~9.9 seconds
Slow-start speed adjustable	L0 : 100%, 35%~85% L1~L9 Rated speed
Running Time limit-LO	0.00~9.99 seconds
Running Time limit-HI	0.0~9.9 seconds
Reminder Mode	ON / OF / FF / EF with LED and buzzer
Auto ZERO	ON / OFF
External inputs	Forward / Reverse / Disable / Confirm / Sensor / Clear
External outputs	OK / NG / OK ALL
Screwdriver Control	HI / LO : Slow-Start
Outside Dimensions	200X130X100(mm)
Weight(Kg)	1.57
Accessories	Power cordX1 · KeyX2
Remark	
Applicable Models	MY2(Series) MY5(Series)

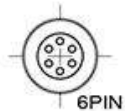

MY2-L (Series)

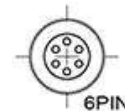

MY2-P (Series)

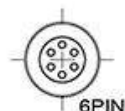

MY5-L (Series)

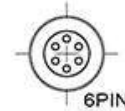

MY5-P (Series)



## KTM-6, KTM-15, KTM-150, KTM-250, KTM-1000

KTM-6 / 15 / 150



KTM-1000



KTM-250



### KTM-6, KTM-15, KTM-150, KTM-250, KTM-1000

- LED can identify the test range of torque setting by needed user. If the result is not complying to torque range setting, light will be warned.
- USB connector is only used for data output : it is convenient for user to work with computer.
- Auto-zero can be selected and zero reset becomes unnecessary for user.
- Automatically test values about maximum, minimum and mean.
- ※ Products are suitable for shut off type screwdriver only.

## Specifications

Model		KTM-1000	KTM-250	KTM-150	KTM-15	KTM-6
Measuring Ranges	(kgf.cm)	50~1000	3.0~250.0	1.5~150.0	0.15~15.0	0.02~8.0
	(Lbf.in)	45~885	3.0~217.0	1.5~130.0	0.15~13.0	0.02~7.0
	(N.m)	5~100	0.30~25.00	0.15~15.0	0.015~1.500	0.2~80.0 (cN.m)
Accuracy		+/- 0.5%				
Power Supply		3.7V, 4400mAH	4.8VDC (Ni-MH chargeable battery 1.2VX4 cell 1650mAh)			
Charging Time		2 hours	From empty -3 hours			
Operation Time		4 hours(non stop)	About 12 hours			
Battery Life		Chargeable for 300 times or more. However, it varies depending on operating conditions.				
Size(mm)		229(W)X102(D)X80(H)	160(W)X210(D)X45(H)	230(W)X125(D)X65(H)		
Weight(kg)		2.7	2.0	1.8	1.2	
Exclusive Charger		Input : AC100V~240V 50/60Hz Output : DC5V 12A		Input : AC100V~240V 50/60Hz Output : DC12V 500mA		
Accessory		Torque measuring adaptorX1 SJ-1000	Torque measuring adaptorX1 AJ-250	Torque measuring adaptorX3 AJ-150 / AJ-50 / AJ-15K	Torque measuring adaptorX2 AJ-15 / AJ-3	Torque measuring adaptorX1 AJ-3

# SCREW FEEDER

## KFA-0820 Series (KFA-0820H, KFA-0820A)



**KFA-0820H**  
(MANUAL PICK UP TYPE)

Prompt delivery and steady screw feeding are the important factors of a screw feeder. We have collected feedbacks from all brands users for their opinions to develop this screw feeder. We integrated our advantages with other brands and eliminated detriments that occurred on other brands. As the result, win situation is provided to both our distributors and customers. Please read operation manual before operating in order to achieve the max value of the screw feeder.

### Other functions

PCB designed with short circuit and over load protection. Screw feeder and PCB grounding connection is also available. Power On/Off buzzer alert and blinking LED indicator.

### Specifications

Model Name & Number	KFA-0820A(H)
Size	160(L)X82(W)X112(H) mm
Weight	1.53kg (w/o adapter)
Power Source	AC 100~240V
Switching Adaptor	DC 12V Switching Adaptor
Applicable Screw	From M1.2~M2.0
Applicable Screw Length	≤ 7 mm
Applicable Screw Dia	≤ 4 mm
Horizontal Delivery Speed	42~90 pcs/min (0.7~1.5 Sec)
Feeding	Chamber Blanking
Scooping Chamber Capacity	4000pcs (for M1.4X4) / 1200pcs (for M2.0X5)

### Features

- **WIDEST RANGE OF APPLICABLE SCREW SIZES :**  
Between 1.2~2.0mm
- **MAX OF SCREWS LENGTH & HOPPER CAPACITY :**  
Screw Length : Up to 5mm (under screw head)  
Capacity of hopper : 4000pcs (for M1.4X4) / 1200pcs (for M2.0X5)
- **APPLICABILITY OF SPECIAL SCREW TYPES :**  
Screw Length : Thread Diameter (1=, 1<1)  
Thickness of screw head 0.2mm  
No jamming or failure occurred with these applicable types and affect productivity.
- **BRUSHLESS MOTOR :**  
Adopting durable made in Japan brushless motor.
- **ADJUSTABLE RAILWAY :**  
High precision wire cut adjustable railway. Adjustable rail, screw size from 0.8mm up to 2.0mm.
- **CIRCULAR LOOP FEEDING :**  
Circular loop feeding, adopting durable aluminum extruded rail.  
Screws are carried on a Circular track for smooth feeding.
- **ADOPTING MULTI-FUNCTIONAL :**  
Adopting multi-functional smart PCB with material shortage alert and screw taking counting function in digital display. ( Please contact our service center for detail information.)
- **SIGNAL OUTPUT FUNCTION :**  
With screws in position signal output function.



**KFA-0820A**  
(VACUUM PICK UP)



**KFA-0850A  
(VACUUM PICK UP)**

## Features

- **WIDEST RANGE OF APPLICABLE SCREW SIZES :**  
Between 0.8~3.0mm (KFA-0830).  
Between 1.2~5.0mm (KFA-0850).
- **APPLICABILITY OF SPECIAL SCREW TYPES :**  
Screw Length : Thread Diameter (1=1, 1<1)  
Thickness of screw head 0.2mm  
No jamming or failure occurred with these applicable types and affect productivity.
- **BRUSHLESS MOTOR :**  
Adopting durable made in Japan brushless motor.
- **ADJUSTABLE RAILWAY :**  
High precision wire cut adjustable railway. Adjustable rail, screw size from 0.8mm up to 5.0mm.
- **HORIZONTAL LINEAR FEEDING :**  
Horizontal linear feeding, adopting durable aluminum extruded rail.  
Screws are carried on a horizontal track for smooth feeding.
- **ADOPTING MULTI-FUNCTIONAL :**  
Adopting multi-functional smart PCB with material shortage alert and screw taking counting function in digital display. ( Please contact our service center for detail information.)
- **SIGNAL OUTPUT FUNCTION :**  
With screws in position signal output function.



**KFA-0830  
(VACUUM PICK UP)**

Prompt delivery and steady screw feeding are the important factors of a screw feeder. We have collected feedbacks from all brands users for their opinions to develop this screw feeder. We integrated our advantages with other brands and eliminated detriments that occurred on other brands. As the result, win situation is provided to both our distributors and customers. Please read operation manual before operating in order to achieve the max value of the screw feeder.

## Other functions

PCB designed with short circuit and over load protection. Screw feeder and PCB grounding connection is also available. Power On/Off buzzer alert and blinking LED indicator.

## Specifications

Model Name & Number	KFA-0830	KFA-0850A(H)
Size	182(L)X124(W)X146(H) mm	182(L)X124(W)X150(H) mm
Weight	3.0kg (w/o adapter)	3.1kg (w/o adapter)
Power Source	AC 100~240V	
Switching Adaptor	DC 12V Switching Adaptor	
Applicable Screw	From M0.8~M3.0	From M1.2~M5.0
Applicable Screw Length	≤15 mm	≤10 mm
Applicable Screw Dia.	≤7 mm	≤7 mm
Horizontal Delivery Speed	46~50 pcs/min (1.2~1.3 Sec)	42~90 pcs/min (0.7~1.5 Sec)
Feeding	Chamber Blanking	
Scooping Chamber Capacity	200~220 c.c	



**KFA-0850H  
(MANUAL PICK UP)**

# SCREW FEEDER

## KFR-1050



Prompt delivery and steady screw feeding are the important factors of a screw feeder. We have collected feedbacks from all brands users for their opinions to develop this screw feeder. We integrated our advantages with other brands and eliminated detriments that occurred on other brands. As the result, win situation is provided to both our distributors and customers. Please read operation manual before operating in order to achieve the max value of the screw feeder.

## Specifications

Model Name & Number	KFR-1050 Automatic Screw Feeder
Size	182(L)X126(W)X147(H) mm
Weight	N.W. : Approx 2.17 Kgs (excluding switching adaptor)
Power Source	AC 100~240V
Switching Adaptor	DC 15V Switching Adaptor
Applicable Screw	From M1.0 to M5.0
Applicable Screw Length	Up to 19mm(under head)
Scooping Chamber Capacity	200~220 cc
Accessories (in package & box)	Allen Wrench (L Shaped 2.0 x 107 mm) X1 pc.
	Switching Adaptor x 1 Set.
	Accessory(front) (0.8 , 1.0 , 1.2 , 1.5 , 2.0 x 70 mm)X1 pc.
	Accessory(behind) (0.2 x 10 x 20 mm)X2 pcs (0.5 x 10 x 20 mm)X10 pcs.
	Stopper 2.0~5.0mmX1 pc.
	Instruction Manual
Package Size	Each Set/Box : 282(L)X142(W)X201(H)mm
	Each Carton : 450(L)X310(W)X435(H)mm
Package Weight (Including Machine)	Each Set/Box G.W : Approx 2.63 Kgs
	Each Carton G.W : Approx 16.53 Kgs(One Carton=6 Sets)

## Features

- WIDEST RANGE OF APPLICABLE SCREW SIZES :**  
 Between 1.0~5.0mm (Incl. : 1.0mm, 1.2mm, 1.4mm, 1.7mm, 2.0mm, 2.3mm, 2.6mm, 3.0mm, 3.5mm, 4.0mm, & 5.0mm,) 11 sizes.
- MAX OF SCREWS LENGTH & HOPPER CAPACITY :**  
 Screw Length : Up to 19mm (under screw head)  
 Capacity of hopper : 200~220 c.c
- APPLICABILITY OF SPECIAL SCREW TYPES :**  
 Screw Length  $\geq$  Thread Diameter (1=1, 1<1)  
 Thickness of screw head  $\geq$  0.2mm  
 No jamming or failure occurred with these applicable types and affect productivity.
- SIZE OF FEEDING RAIL IS ADJUSTABLE :**  
 Feeding rail can be pulled out for width adjusts to the applied sizes easily. Measurements for width adjusting can be in metric or imperial units.
- SAVE PARTS COSTS & STOCK :**  
 KFR-1050 allows adjusting the width of feeding rail to serve 11 sizes screws, between 1.0mm to 5.0mm diameter. The flexibility prevents dealers from stocking up on quantities for different sizes, and reduces the cost on related accessories for users.
- ADJUSTABLE VIBRATION INTENSITY :**  
 With vibration in small amplitude at high strength, it moves screws On rail to pick-up point in good order, no overlap or jamming to affect the speed of movement and productivity.
- HUMANIZED MULTI PROGRAMMING CONTROL:**  
 \*Individual drive system for feeding and vibrating operation.  
 \*Setting for suitable stop time without interapt to operate.  
 \*Equipped ground wire, socket & buzzer for operative safety and alarm signal.  
 \*PCB controls for efficiencies of desired speed & timing on each operating step.  
 \*Switching Adaptor allowed AC 100~240V power source for stable DC 15V output No influences and problems due to the different AC power source of factories locations.

## Other functions

PCB designed with short circuit and over load protection. Screw feeder and PCB grounding connection is also available. Power On/Off buzzer alert and blinking LED indicator.



## KP-AUX Series



KP-AUXA, KP-AUX1T

### Auxiliary Arm

#### KP-AUXA, KP-AUX1T

- Provide with the rocker arm, enable to revolve on 360 degrees.
- Main shaft can be extended to maximum 830mm
- Power arm inside includes nitrogen gas stick, allow user to grab the arm easily, automatic lift up to position after finishing the work.
- Easy to assemble and Disassemble.
- Optional accessory KP-VA1, KP-VAR(90 degree adapter) is available for user to Adjust angle in accordance with the object to be fastened.



KP-VAR, KP-VA1

Model	KP-AUXA	KP-AUXA-1	KP-AUXA-2	KP-AUX1T-B	KP-AUXA-500
Description	Cantilevered	Cantilevered	Cantilevered	Cantilevered	Cantilevered
Reach	50mm~830mm	50mm~830mm	50mm~830mm	50mm~830mm	50mm~830mm
Gas Stick	25kg	30kg	25kg	25kg	35kg
Applicable Models	MYR Series MYR 1235/2050 Series Not included	MYR Series	MY9 Series	MY7 Series MY8-EP Series	MYR-1235 Series MYR-2050 Series
Remark	—	KP-VAR Optional Accessories	—	KP-VA1 Optional Accessories	KP-VA2 Optional Accessories

※The auxiliary arm can be used only with MYTORQ electric screwdrivers.

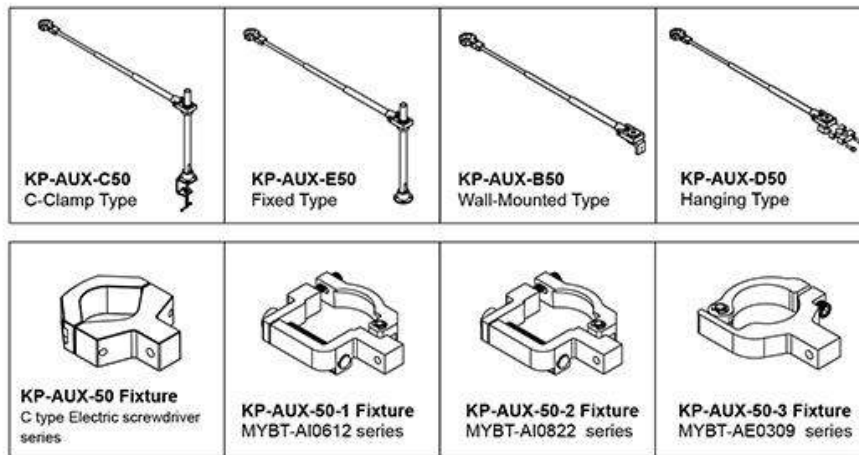

### Specifications

Model No.	Max torque (Nm)	A(mini/maxi) cm	Tool Ø diameter(mm)
KP-AUX-C50-1000	50	43~100	38.5~52
KP-AUX-C50-1200	50	50~120	38.5~52
KP-AUX-E50-1000	50	43~100	38.5~52
KP-AUX-E50-1200	50	50~120	38.5~52
KP-AUX-B50-1000	50	43~100	38.5~52
KP-AUX-B50-1200	50	50~120	38.5~52
KP-AUX-D50-1000	50	43~100	38.5~52
KP-AUX-D50-1200	50	50~120	38.5~52

※Please inform which screwdriver series will be with the auxiliary arm before releasing order.

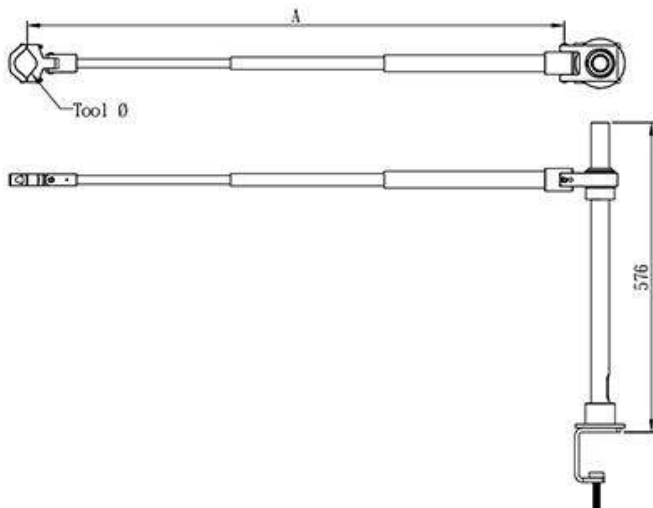

# SCREWDRIVER I/O SIGNAL CONTROL BOX, SLOW START CONTROL MODULE, 90 DEGREE ATTACHMENT

[MY-SIO, KL-SSBN, KL-2]

## Screwdriver I/O Signal Control Box(For Manual / PLC)



### MY-SIO

- Slow Start time (0.0-9.9 second)
- Slow start Speed (30%-100% of normal speed,L0-L9)
- Operation Time (0.0-9.9 second)
- Target Reached Confirm (enable / disable)
- Brake Signal Hold Time (start off / next start off)
- External Start Input Control
- External Reverse Input Control
- Signal output (Start,Stop,Reverse)



MY5

+



MY-SIO

+



MYP series Power Controller



## Slow Start Control Module

### KL-SSBN

- BYPASS: Automatically disable slow start function when screwdriver in reverse rotation, easier to reverse screws.
- Adjustable slow start speed from 30% to 100% of normal speed, Slow start level setting from L1-L2-L3-...L9-L0
- Provide output start signal/ break signal/ forward and reverse signal with MOS relay switch
- Compatible with MYTORQ Brushless DC MY2 / 5 series
- Slow start time can be set from 0.1 s up to 9.9 second
- Dimension : 58x95x35mm (LxWxH)

## 90 Degree Attachment



KL-2

## Specifications

Model	90 Degree Attachment Applicable Model
KL-2	MY5 Series

※ Only for "L" trigger start screwdrivers

	Screwdriver Holder	KH-2	KH-3	KH-4	KH-5
	Applicable Models	MY5-EP	MY-5 (Screwdriver with Torque Locker)	MY-5 (Screwdriver W/O Torque Locker) MY5-EP (Screwdriver with Torque Locker)	MY-2 MY2-EP

	Torque Locker	KC-6C(S)	KC-13C(S)
	Applicable Models	MY-5 MY5-EP	MY-2 MY2-EP

ESD need special order (S) series.

	Spiral Cables
	Supplying spiral cables for all of MYTORQ screwdrivers with 6pin. (MY2 series are not included.)

 <p>KW-1    KW-3    KW-4</p>	Torque Adjuster	KW-3	KW-4
	Applicable Models	MY-5 Series MY5-EP Series	MY-2 Series MY2-EP Series

	Pistol Grip	Applicable Models
	LG-10	MY5(L) Series
	PG-10	MY5(P) Series
	LG-11	MY5-EP(L) Series
	PG-11	MY5-EP(P) Series

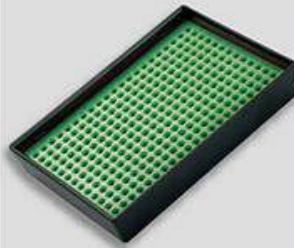
	Screw Setter	Applicable Models
	KB-1	M1.7~2.0 Screw available
	KB-2	M2.0~2.6 Screw available
	KB-3	M3.0~4.0 Screw available

	Spring Balancer	Applicable Models
	KL-600 (0.3~0.6kg)	MY2 Series, MY2-EP Series
	KL-1200 (0.6~1.5kg)	USE FOR ALL MODELS (MY9 and MYT, MYR, MYLR series are not included.)



**TAIWAN  
EXCELLENCE  
2018**

**MYTORQ**  
ANLIDAR INDUSTRIAL CO.,LTD.  
<http://www.anlidar.com>  
EN2018.10



Taiwantrade  
Supplier  
Business  
Information  
Verification



[www.tuv.com](http://www.tuv.com)  
ID 0000049735

